

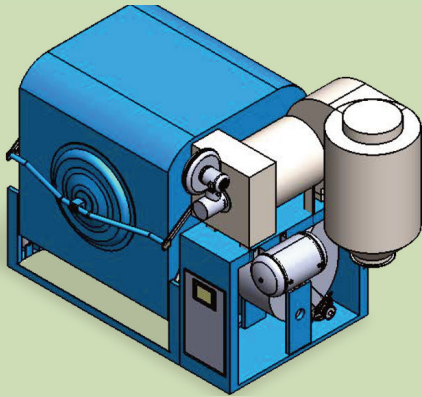

MODEL 140GP



- 140 cu. ft. vol. Basket
- Compact Gas Heated
- Two-Door Pass-Through
- One-Way Tilt
- PLC Control

RECOMMENDED CAPACITY

300-400 lbs. dry weight.

ELECTRIC MOTORS

- Exhaust blower 15 hp
- Basket drive 5 hp
- Burner blower 3/4 hp

SHIPPING WEIGHT

7,500 pounds

NOTE:

Also available in 1 or 2-Door,
2- Way Tilt Configurations
Lo-NOx Burner Option
Available

BASKET:

The 140 cu. ft. basket frame is constructed of top quality 10-gauge steel with three main lifting ribs, three secondary lifting ribs, and six removable perforated panels for trouble-free maintenance. The basket is supported by four 10" polyurethane rollers and guided at both ends by four 5" polyurethane rollers. All CLM wheels are equipped with Timken roller bearings and located outside of the sealed heating chamber.

BASKET DOORS:

Consolidated's revolutionary basket door seals to and rotates with the basket to prevent damage to products being dried. The doors operate by an air over oil mechanism for smooth opening and closing, and are available with load door diameter options of 42" or 48" inches. Standard models include two basket doors providing for loading at one end and unloading at the opposite end of the basket.

BASKET DRIVE:

The basket is driven by v-belts around the circumference of the basket. There is a self-adjusting, constantly variable tension device to keep the belts properly tensioned. The belts are located outside of the sealed heating chamber. The basket drive also gives a component-saving inverter for basket start-up and for basket reversing..

MACHINE TILT:

The main housing tilts to a maximum 18° facilitating fast and easy loading and unloading of the machine. The tilt mechanism contains two 5" i.d. double-cushioned air cylinders.

Lo-NOx HEAT SYSTEM:

A high-efficiency burner is coupled to a full flame spectrum modulating system with pre-air/gas mixing for proper combustion before entering the drying chamber. The combustion chamber is constructed of a steel inner chamber with a steel outer jacket separated by a cooling space using the intake air as an insulator and to pre-heat the incoming air. Maximum firing rate of the burner shall be 2,500,000 btu/hr and average firing rate shall be 1,050,000 btu/hr at 26" wc pressure.

HEAT CONTROL:

The flame modulation and temperature is PLC controlled and programmed to heat by inlet/outlet temperature, automatically or by time. Cool-down is also controlled by time or to programmed temperature.

EXHAUST SYSTEM:

The exhaust blower is single inlet, dynamically balanced and belt driven from a 15 hp motor to afford a minimum air flow of 9,800 cfm. Included is a device to automatically clean accumulated lint from the rotor at the beginning of each cycle.

STANDARD OUTSIDE AIR MAKEUP:

A means of providing makeup air directly to the burner and combustion chamber from outside the plant to prevent negative air pressure within the plant. The inlet duct has an inside dimension of 15" x 32.5".



MODEL 140GP

SERVICES:

ELECTRICITY

Varies with voltage characteristics
70 FLA at 230 VAC
35 FLA at 460 VAC

AIR

1/2" NPT connection
80 psi minimum

WATER

3/4" NPT connection
80 psi minimum

GAS

2" NPT connection
26" wc minimum

EXHAUST DUCT

Minimum 24" diameter or 460 sq. in.
Maximum 1.0" wc backpressure

STAINLESS STEEL DRY LINT COLLECTOR OPTION:

If purchased, a stainless steel lint collector will be integrated with the dryer. Included with this option is an internal air receiver for end-of-cycle lint blowdown, and a separate dedicated fire suppression system with alarm. The transition from dryer to lint collector comes factory installed, and separate utility connections are not required. The 24" exhaust duct, to the atmosphere, is the only connection required. Lint shall automatically be removed into a lint bag or drum at the end of each cycle.

PLC CONTROLS SHALL PROVIDE:

- A. 10.4" Color Touchscreen HMI to program and control machine functions including but not limited to start/stop, reverse/non-reverse selection and recirculation time.
- B. Detailed machine overview screen displays inlet/outlet temperatures, time, program number, faults, dryer cycle, excess exhaust back-pressure and other pertinent information.
- C. 96 user programmable drying formulas with multi-level password protection to prevent operators from overriding management decisions.
- D. Ability to customize dry/cool down processes by either time or inlet/outlet temperatures.
- E. Unique AutoDry™ feature helps take the guess work out of heat cycle termination without the complication and cost of humidity or infrared sensors.
- F. Capable of transferring programs to other CLM dryers with PLC controls.
- G. Control full-flame-spectrum modulation with 40:1 turndown ratio.
- H. Lint trap controls with optional CLM lint collector.

INTERLOCKS, SAFETY DEVICES & OTHER FEATURES SHALL CONSIST OF:

- Automatic fire safety suppression system with alarm
- Exhaust blower rotation sensor
- Blower burner rotation sensor
- Basket rotation sensor
- Tilt interlock safety switches
- Door safety switches
- Guards on moving parts
- Tilt and door warning bell
- Electrical interlock to prevent door and tilt malfunction
- Door opens on power failure
- Fireeye flame protection device
- Automatic gas shutdown in case of increase or reduction in gas pressure (option).
- Circuit breaker w/mechanical interlock to prevent opening of electrical panel with power on.
- Thermal overload protection devices for all motors
- Both hands required to close doors
- Manual fire suppression system switch with guard to prevent accidental activation
- Bell and light to indicate end of cycle
- Momentary basket jogging switch



MODEL 140GP

